

**Somfy Digital Network
(SDN)
Installation and
Programming**

Table of Contents

I	General Information and Features	3
1.1	ILT2 Motor	3
1.2	SDN Switches	4
1.3	ILT2 Tap	5
1.4	Bus Power Supply	6
1.5	ILT2 Motor Configuration Software	6
1.6	SDN Switch Configuration Software	6
1.7	Data Cable Extension Kit	7
1.8	IR Transmitter for SDN Switch	7
1.9	Local Switch	7
1.10	RTS Receivers	7
1.11	Local IR Receiver and Transmitter	8
1.12	RS485 Segment Bridge	8
1.13	IP Interface	8
1.14	System Overview	9
2	Programming the ILT2 Motor	10
3	Programming the SDN Switch	19
4	General Installation Notes	21

1 General Information and Features

The Somfy Digital Network is the latest generation of bus-line controlled Tubular Motors and controls. The network is RS485, half-duplex, bi-directional.

The SDN consists of the following components:

- ILT2 & ST-30 RS485 Motors
- SDN Switches (3 and 6-button)
- ILT2 Tap
- Bus Power Supply
- ILT2 Motor Configuration Software
- SDN Switch Configuration Software
- Standard Cat 5 Cable and splitters
- RJ9 to RJ11/12 converter and RJ12 modular cable

Optional Accessories:

- IR Transmitter for SDN Switch
- Local Switch
- Local RTS Receiver
- Bus line RTS Receiver
- Local IR receiver and Transmitter
- IP Interface
- RS485 Segment Bridge

1.1 ILT2 Motor

The ILT2 motor has a 1.5 m power cable with a NEMA 15-5 molded plug and a low voltage RJ9 modular connector in the head of the motor for data. The motor is shipped with a 1' data cable attached. All parameters of the motor, except end limits*, are programmable over the network as described in section 2. Limits must be set using the ILT switch (#1800410) or the ILT limit setting tool (#9050280). The ILT Address Reader (#9015137) can both read the address of the motor and set limits – applies to ILT2 motor only.

*End limits can be adjusted via software once initially programmed via limit setting tool.

Features of the ILT2 Motor:

Unique Address: Each motor is given a unique 3 byte address at the time of manufacture.

16 Intermediate positions: Each motor can store up to 16 preset positions.

16 groups: Each motor can be a member of up to 16 groups.

Standard positioning: Includes UP, DOWN and STOP.

Relative positioning: The motor can be positioned as a percentage of its travel range (e.g. 50%).

Precision positioning: The motor can be positioned using encoder pulses.
 Jog movement: The motor can move in small increments for use in tilting horizontal blinds.
 Digital text label: The motor supports a 32 character label that can be queried over the network.
 Half Duplex bi-directional communication: The motor can be queried for stored parameters.

1.2 SDN Switches

Presently there is a Decora™ style white 3-button (#1810827) and 6-button (#1810828) SDN switch available. The switches are powered from the network and draw 10 mA each. There is a “power on” LED on the back of the switch.

The function of each push button is programmable and can have three functions as follows:

- On Push (activates within 500 ms if On Hold not active)
- On Hold (activates after 1.5 seconds if active. In this case On Push is ignored)
- On Release (activates within 500 ms of release if active)
- Sequential (press 1: UP, press 2: STOP, press 3: DOWN, press 4: STOP, etc.)

Programming the switch is accomplished using the SDN Configuration software as described in section 3. The switch includes an RJ45 connector for network connection.

The SDN switches are IR compatible. In addition there are 8 dry contacts (and common) inputs. Dry contacts must be momentary (1.5 sec) and are mapped to the push buttons. If push button #1 is UP LIMIT, then by default so is dry contact #1.

The SDN switches mount in standard single-gang device boxes.

3 - Button Switch

6 - Button Switch

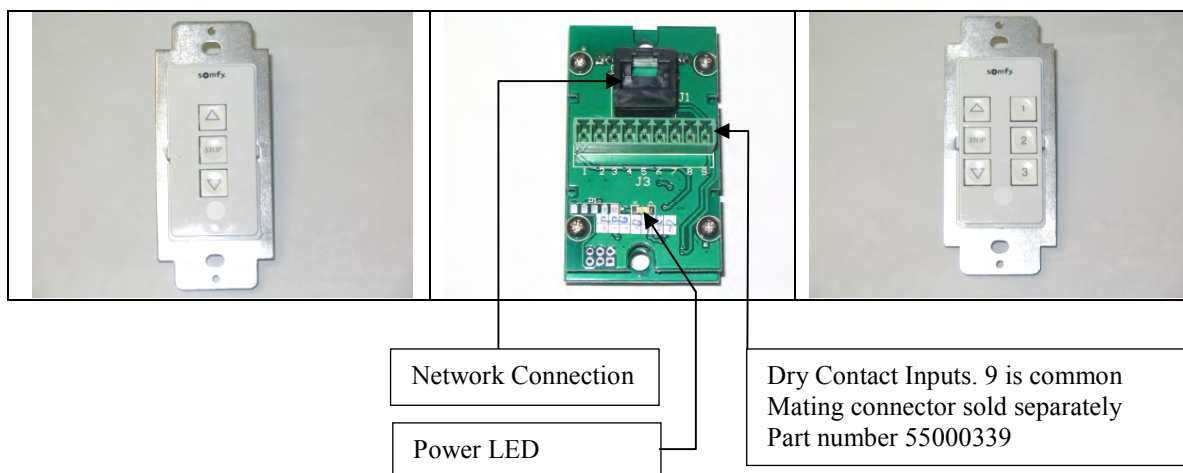

1.3 ILT2 Taps

#1870154 & #1870127

The Tap converts the ILT2 command set from RS485 to TTL which is required by the motor. It requires 12-24 VDC to operate (see section 1.4) which is supplied over the network. Each Tap draws 7 mA.

Each motor attached to a Tap can be controlled individually over the network. However, local control inputs will activate every motor connected to the Tap as a group.

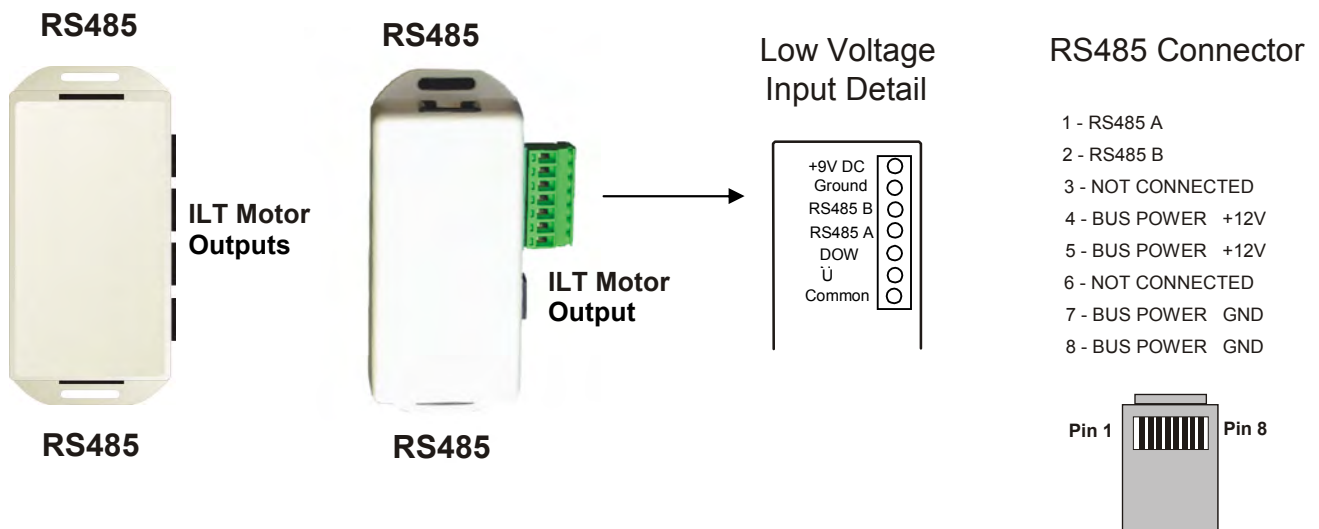

UP/DOWN/COMMON of the low voltage screw terminal is local control. All motors connected to the Tap operate as a group.

1.4 Bus Power Supply

The Taps require 12-24 VDC power. Typically the power is connected to the first Tap using the screw terminals. Power is then distributed to each Tap over the Cat 5 cable. As an alternative, power can be supplied through the RJ45 on the first Tap if the proper adapter is used.

Presently Somfy has available a 12 VDC 1A plug-in transformer (#1822111) and a 24V 1.25A table top transformer (#1822209). As an option, additional transformers can be installed mid-segment as follows:

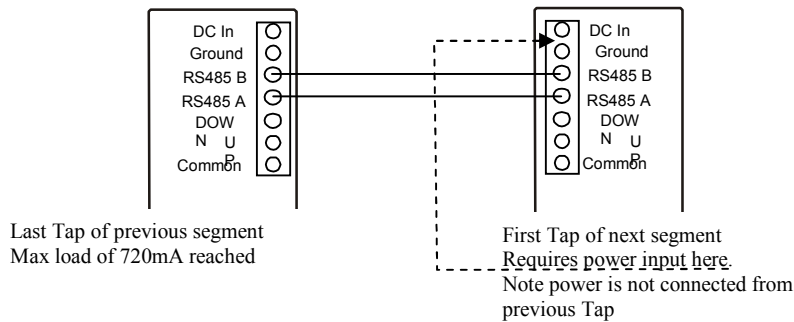

The **maximum current** for any one network segment is 720 mA.

A termination resistor is included with each Tap, however they are only installed on the extreme ends of a network segment. The resistor is connected between RS485 A and B. Many installations will not need any termination resistors. Segments with less than 50 network devices and 600' of CAT 5 cable will not need the termination resistors.

The above wiring method is not intended as RS485 bridge and will not increase the node count.

1.5 ILT2 Motor Configuration Software

The ILT2 motor configuration software is a Windows based application program that allows the motor address to be read (read-only) and motor parameters to be read and written. Section 2 covers this in detail.

1.6 SDN Switch Configuration Software

The SDN Switch configuration software is a Windows based application program that allows the switch address and parameters to be read and written. Section 3 covers this in detail.

1.7 Data Cable Extension Kit

#1810817

The ILT2 motor comes with a 1' data cable installed. The data cable is terminated with a RJ9 (handset) connector. In most cases the motor will be more than 1' away from the nearest Tap so a means to lengthen the cable is needed. As RJ9 parts are difficult to find, this extension kit allows the motor data cable to be lengthened (10 m max) using widely available RJ11/12 cable and connectors. Cables must be straight thru and not crossed. The kit includes two RJ9 to RJ11/12 couplers and a RJ12 to RJ9 patch cable. Together with standard RJ11/12 modular cable the data cable can be easily lengthened. The parts are used as follows:

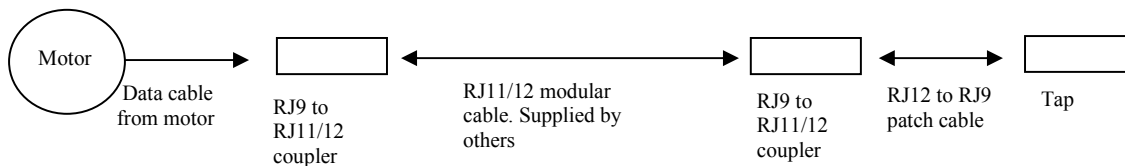

1.8 IR Transmitter for SDN Switch

Somfy's 8-channel transmitter (#1870010) can be used to activate the SDN switch. The IR buttons labeled 1 – 8 are mapped to the push buttons on the switch. If push button #1 is programmed as IP #1, channel #1 of the transmitter will serve the same function.

1.9 Local Switch

The local switch (#1800406, white) is connected directly to the Tap using the screw terminal inputs. The local switch (#1800410) is connected to the Tap using an RJ9 splitter is using the single style Tap, or directly to the RJ9 port if using a 4 motor Tap. The two versions of the local switch are identical from the user's standpoint. They do not require power.

1.10 RTS Receivers

The local RTS receiver can be connected directly to the Tap or using the RJ9 splitter. The receiver is powered by the motor. Any compatible Somfy RTS transmitter can be used. Part # 1810613.

The bus line RTS receiver can be directly connected to the bus by means of a RJ45 splitter. The receiver is powered by the bus line while any compatible Somfy RTS transmitter can be used. Part # 1822294.

1.11 Local IR Receiver and Transmitter

The local IR receiver (#9154205) must be connected to the motor and Tap. The receiver is powered by the motor. The transmitter (#1810561) is a single channel unit and will activate any sensor in range.

1.12 RS485 Segment Bridge

#1810816

There can be a maximum of 256 nodes on any one segment. If an installation requires more than 256 nodes, (i.e. Taps and SDN Switches) a RS485 Segment Bridge must be used. The bridge simply “jumps” the RS485 signal from one segment to the next. Includes a plug-in transformer.

1.13 IP Interface

#1810850

The IP Interface is a serial device server used to connect Somfy ILT2 motors and control devices to an IP network. The firmware is remotely upgradeable through HTTP port 80, un-proxied. The IP Interface contains an embedded web server and configuration software that is accessed via any standard web browser and is therefore compatible with both PC and Mac platforms.

GUI button text and function can be personalized. GUI can be created and accessed from a link on your desktop for complete solar shading control. All GUI actions have associated URL commands for interfacing with 3rd party IP control systems.

Completely automated shade movements can be programmed via the time scheduling and solar angle utility.



IP Interface Specifications:

Ethernet: 10/100 Mbps, RJ45
 Protection: Built-in 1.5 KV magnetic isolation
 RS 485, half duplex using adapter
 Transmission speed: 1.2 – 115 Kbps
 Power: 300 ma @ 12 VDC
 Dimensions: 2.9” X 1.0” X 3.8”

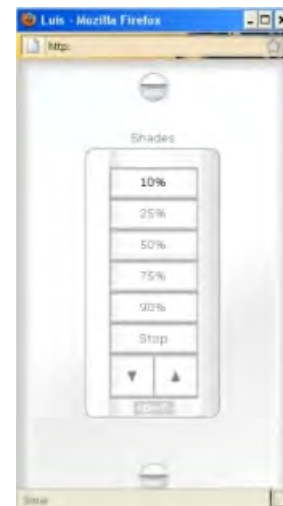

GUI

Somfy Digital Network ILT2 Diagram

- 256 Max. Nodes (tap or network switch)
- 4000 Feet Max. Network Cable Length
- 30 Feet Max. Tap-to-Motor Cable Length

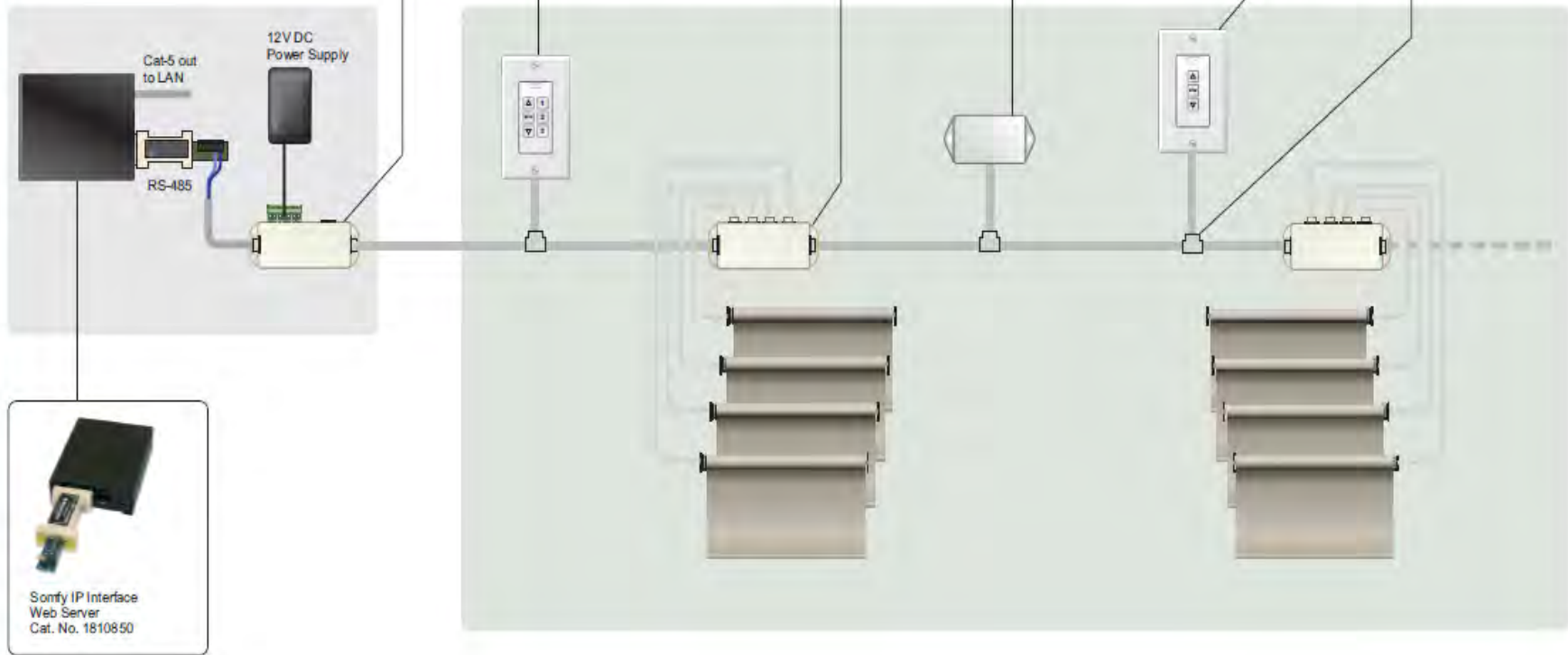
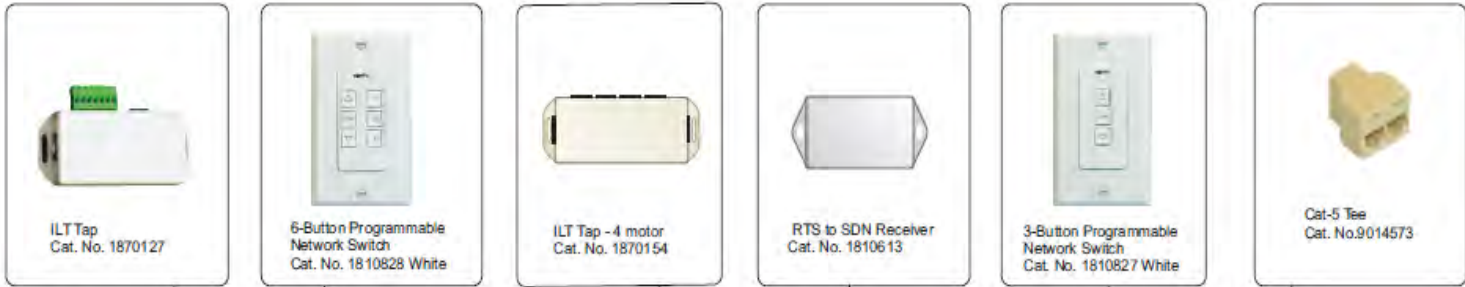

2 Programming the ILT2 & ST-30 RS485 Motors

- * Before installing the shades, the motor address should be read and recorded. This is best done at the time of fabrication. Ideally the addresses are recorded on a CAD drawing of the building or home for future programming, labeling and reference. If the addresses are not read prior to installing the shades, then the installer will have to access each motor head to read the address. This is time consuming and labor intensive.

ST-30 RS485 motors are supplied from the factory with three removable node id labels. These can be torn off and placed on the shade packaging, order forms, or CAD drawing.

- * In order to read and write data to the motors and switches, it is best to use a laptop and a USB to RS485 serial adapter. Somfy recommends B&B Electronics 485USBTB-2W. It is available for \$85.00 at http://www.bb-elec.com/product_family.asp?familyid=397.

*

To set up the USB RS485 adapter

1. Install the driver accompanied with the device.
2. Find the Com Port that the USB/RS485 adapter was assigned to.
3. Click on the Com Port
4. Click on Port Settings Tab (bottom of page) and set the following:

a. Baud Rate	4800
b. Data Bits	8
c. Parity	Odd
d. Stop Bits	1
e. Flow Control	None
5. Click on OK to save settings.

- Next, install the IL2 motor software by running the SETUP program on the CD provided.
- After installing the software, run it from the drop down menu. After installing the ILT2 motor configuration software and starting it, the next screen you will see is:

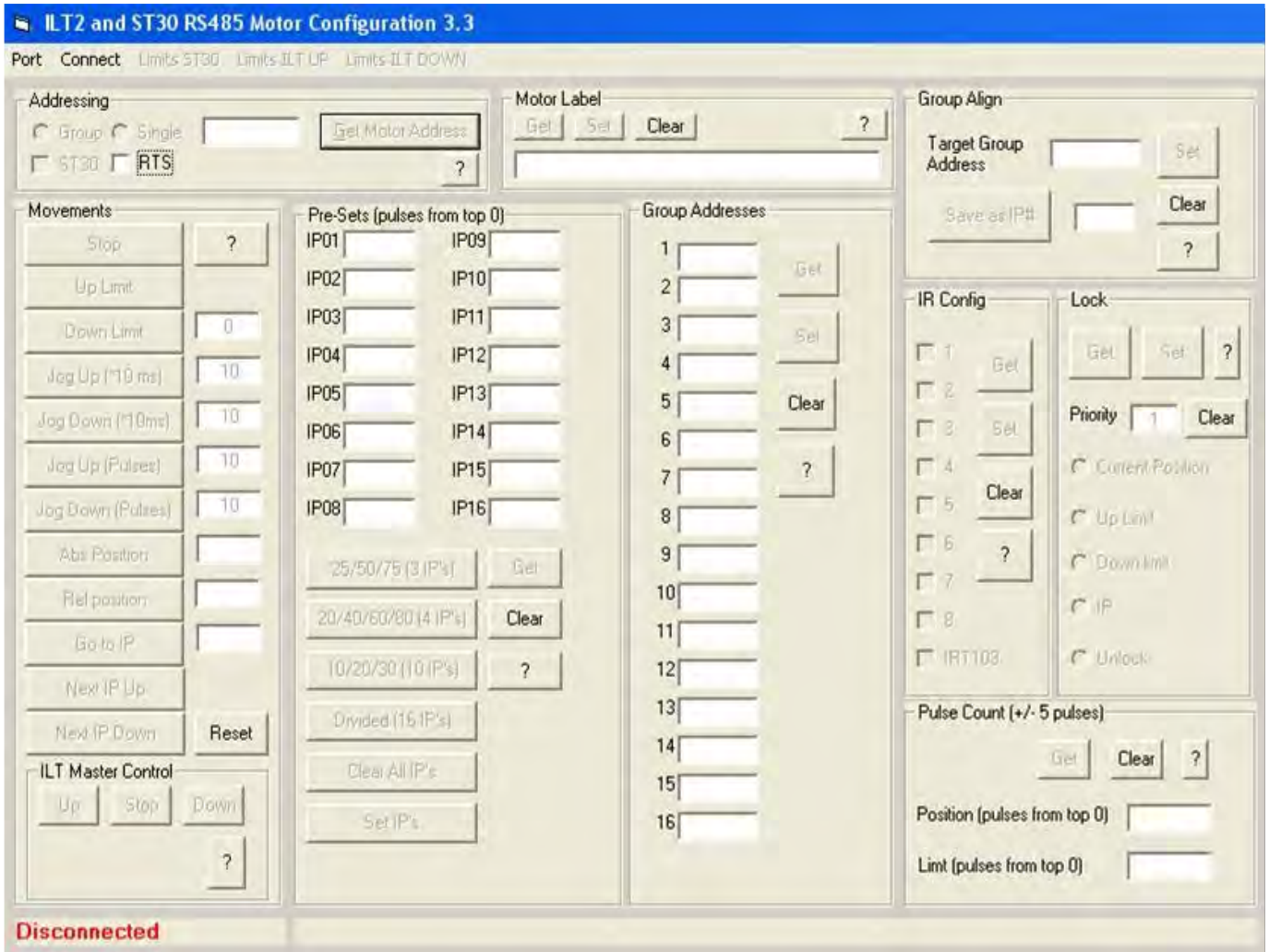

Prior to the start of programming, choose the port number that the USB/RS485 is plugged into and click CONNECT. The bottom left portion of the screen should change from Disconnected in red text, to Connected in green text.

Addressing: This section is used to

1. Read the address of a single motor - only one motor on the network is allowed for this function
2. Enter the address of a motor or RTS to SDN receiver to program or activate – check RTS
3. Enter a group address to activate or program a group of motors

- Click ST30 if working with Sonesse 30 motors..



Leave unchecked for ILT



Notice for Sonesse 30, an additional textbox and button named CALC will appear. This text box has two purposes: (1). If reading the address of a single motor, the new textbox will display the address in the same form as the label on the motor. (2) you can enter the address as printed on the label and click CALC. The program will display the motor address in the form that will be transmitted on the bus in the text box next to Get Motor Address.

Read the address of a single motor: with only one motor connected, click Get Motor Address. The motor address will appear in the text box. You can use this address to move or program the specific motor. If this function is activated with more than one motor connected, the address returned will be invalid.

If you know the address of a single motor, enter it in the address field and click SINGLE. You can now activate and program the motor. If an incorrect address is entered, clicking on single will produce an error.

To activate or program a group of motors, enter the group address and click GROUP. Some functions are not available to program as a GROUP, such commands will be disabled.

Adjusting ST 30 Limits: Clicking Limits ST30 in the menu bar will activate the limit adjusting routine. Motor(s) must be at a limit for this function to work.

Procedure, single motor: Enter the motor address in the address field and click SINGLE, or if only one

Adjusting ILT Limits: Clicking Limits ILT UP or Limits ILT DOWN in the menu bar will activate the limit adjusting routine. For UP adjust, motor(s) must be at the up limit. For DOWN adjust motor can not be at lower limit.

Procedure, single motor: Enter the motor address in the address field and click SINGLE, or if only one motor is connected you can click Get Motor Address. Move the motor to the limit to adjust. Click Limits ILT UP or Limits ILT DOWN from the menu bar. You can now jog the motor in either direction in pulses - 10 minimum.

Procedure, group of motors: Enter the group address in the address field and click GROUP. Move the motor(s) to the limit to adjust. Click Limits ILT UP or Limits ILT DOWN. You can now jog the motors in either direction in pulses - 10 minimum.

When done adjusting the limits, click Normal from the menu bar to return to normal operation..

- **Motor Label:** A character text label used to identify each motor.

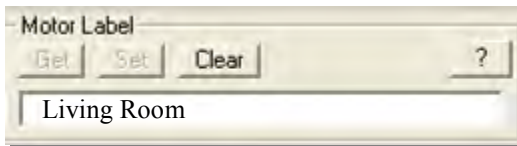

- **Movements:** There are several movement commands that act on a single motor or a group of motors depending on what is selected in the Addressing frame. Some commands require additional information as described below.

STOP: Stop the motor at current position

UP: Move to upper limit

DOWN: Move to lower limit. Text box is for optional roll up time in 10ms increments (10 - 255) after limit is reached

JOG UP: Momentary up movement in 10ms increments (10 -255) as entered in the text box

JOG DOWN: Momentary down movement in 10ms increments (10 -255) as entered in the text box

JOG UP PULSES: Momentary up movement in pulses (10 - 255) as entered in the text box

JOG DOWN PULSES: Momentary down movement in pulses (10 - 255) as entered in the text box

ABS POSITION: Encoder pulse position, must be between 0 to down limit value

REL POSTION: 0 - 100%, 0 is the upper limit

GO TO IP: move to IP 1 - 16 if set

NEXT IP UP: move to next IP up if set

NEXT IP DOWN: move to next IP down if set

Movements	
Stop	?
Up Limit	
Down Limit	0
Jog Up (*10 ms)	10
Jog Down (*10 ms)	10
Jog Up (Pulses)	10
Jog Down (Pulses)	10
Abs Position	
Rel position	
Go to IP	
Next IP Up	
Next IP Down	Reset
ILT Master Control	
Up	Stop
Down	
	?

- **Pre-Sets:** The motor can store up to 16 programmed pre-sets (e.g. Intermediate Positions or IP's). The configuration software can calculate the IP's based on the travel range or the user can set specific positions by entering an encoder value. The values in the 16 text fields represent encoder pulses from top 0. Only values within the travel range are allowed. Values outside the range will generate an error.

Pre-Sets (pulses from top 0)

IP01	1345	IP09	
IP02		IP10	
IP03		IP11	
IP04		IP12	
IP05		IP13	
IP06		IP14	
IP07		IP15	
IP08		IP16	

25/50/75 (3 IP's) Get

20/40/60/80 (4 IP's) Clear

10/20/30...90 (10 IP's) ?

Divided (16 IP's)

Clear All IP's

Set IP's



Pulse Count (+/- 5 pulses)

Get Clear ?

Position (pulses from top 0) 1345

Limit (pulses from top 0)

By clicking one of the five pre determined IP the IP text boxes will auto fill.

- 1) 25/50/75%
- 2) 20/40/60/80%
- 3) 10/20/30....90%
- 4) 16 IP's equally spaced

To write the IP's to the motor click Set IP's.

- Group Addresses:** Each motor can be part of 16 different groups. Enter the 3-byte address here. Group addresses are used by controlling devices such as smart switches and the IP interface to activate groups of motors.

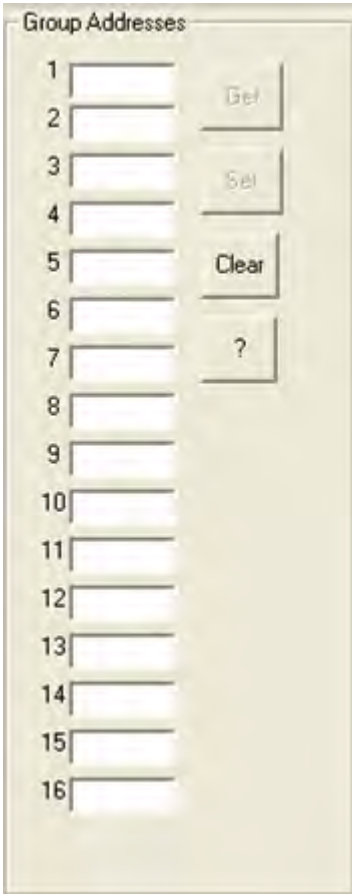

The screenshot shows a vertical list of 16 input fields, numbered 1 through 16. To the right of the first four fields are buttons labeled 'Get', 'Set', 'Clear', and '?'. The rest of the fields are empty.

Group Address Example:

00 00 01
 ┌─┬─┬─┐
 1 2 3 - bytes

Procedure: To program a Group Address it is best to obtain the already programmed addresses first by clicking on GET. The 16 group addresses will be displayed. Default group address for all locations is FFFFFFFF. To change an address, enter the group address in any of the 16 locations and click SET. It is a good idea to GET the addresses after programming to make sure the correct address has been entered. The clear button erases the screen but does not program the motor. If during programming an ERROR is displayed, simply resend the data.

- **Group Align:** This function is used to set an IP of several motors based on an IP setting of another motor (MASTER motor). All motors that are intended to be programmed from this function must share a GROUP ADDRESS.



Procedure:

- 1) Enter the address of the MASTER motor whose IP is to be copied into the motor address field -next to Get Motor Address.
 - 2) Move the MASTER motor to the desired IP location.
 - 3) Enter the group address into the TARGET GROUP ADDRESS field and click SET. All motors will move to the same location as the MASTER motor.
 - 4) Choose an IP position to store the present motor position and click SAVE AS IP#. All motors will now share the same IP position.
- **IR Configuration:** The ILT2 motor can be directly controlled using the single channel IRT103 transmitter or any combination of channels of the IRT803 transmitter. The motor can not be controlled by both the IRT103 and IRT803. The IR sensor is wired in parallel with the TAP.



Procedure: Select any or all of the IRT803 channels or the IRT103 and click SET. Activating the SET command with no channels selected will cause the IRT103 to be chosen. Use the GET command to see what transmitter and channels are active. The CLEAR button deselects all channels but does not program the motor.

- Lock Function:** Motor(s) can be locked at Current Position, Up limit, Down limit (with optional partial roll up after down limit is reached - enter number of 10 ms UP movements in text box. For example enter 100 for 100 X 10 ms = 1 sec) or at an IP Position. There is a priority associated with the LOCK command of 1 - 100. 100 is the highest priority. The LOCK command is also used to UNLOCK the motor if a higher priority is used than was used to lock the motor. The GET command will return the priority level but not the lock position.



- Pulse Count:** The ILT2 motor uses an encoder to determine position. By definition the upper limit is defined as pulse count 0 and the lower limit as the maximum pulse count for full travel for a given shade. Use the GET command to see where the motor is in relationship to either limit and what the pulse count is for the lower limit. The CLEAR command erases the information from the screen but does not program the motor. Knowing the pulse count is helpful when setting IP's and limits.



3 Programming the SDN Switch

Next, install the Switch Configuration software and run it from the drop down menu. Unless changed, the drop down menu will be labeled Somfy and the program will be named SomfySwitch.exe. After starting it for the first time, the program may ask that you pick an active COM port. Choose the port that the USB/RS485 serial adapter is connected to and click CHANGE. Exit the program and restart it.

The next screen is as follows:

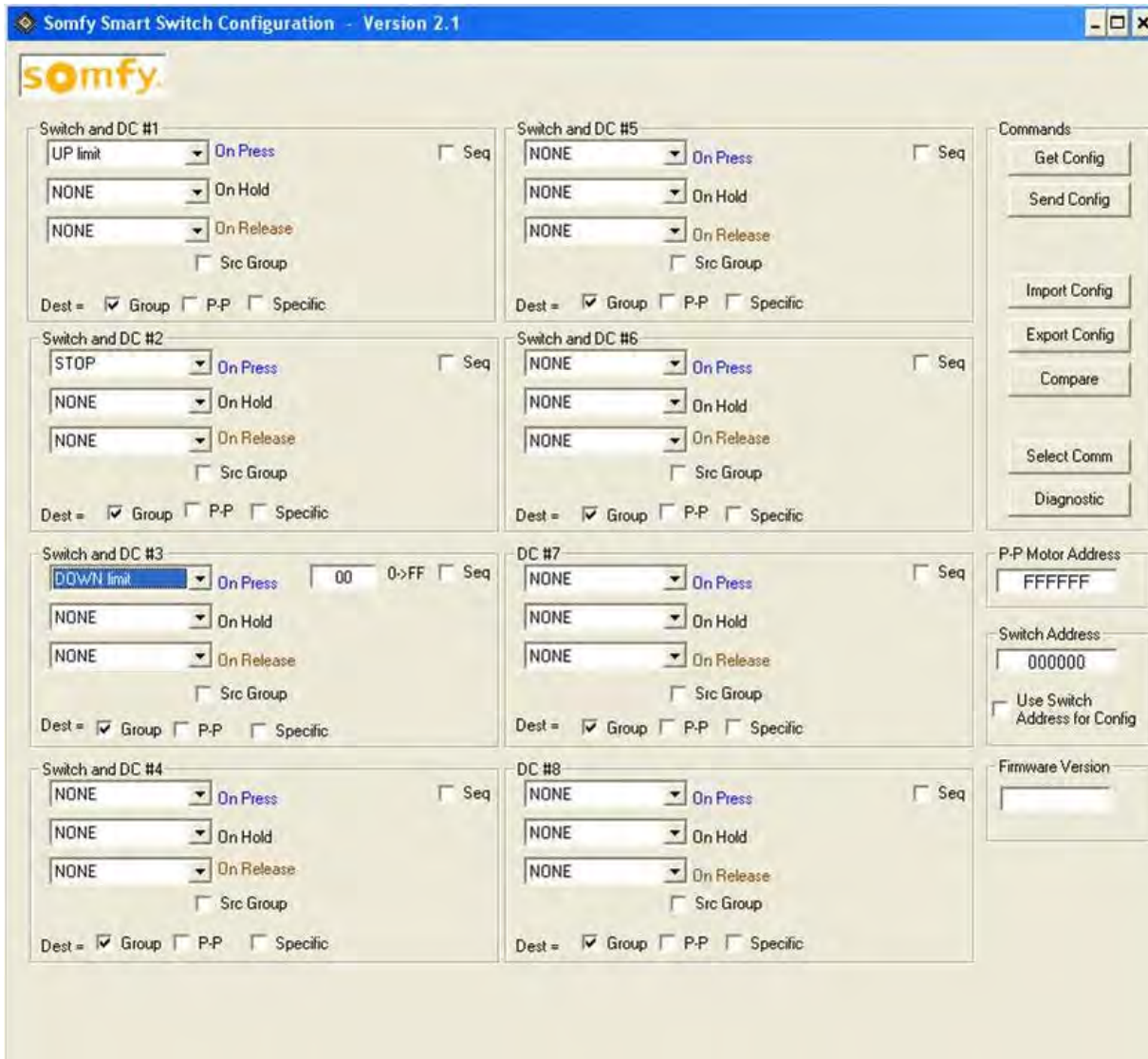

Overview: There are 8 identical sections labeled Switch and DC #1 – Switch and DC #6, DC #7 and DC #8. Switch and DC #1 through Switch and DC #6 correspond to the push buttons on the SDN switches. The dry-contact inputs are also identified as DC #1 – DC #8. Since there are only a 3 and 6-button switch available, DC #7 and DC #8 do not have a push buttons associated with them.

There are three programmable functions for each push button: On Press, On Hold and On Release. Although all commands are available for each switch action, care must be taken not to program conflicting commands for any one push button. For example it would not make sense for a push button to be programmed as follows:

On Press = Up Limit, On Hold = None, On Release = Down Limit

There are many combinations of commands that would not be practical.

There are 3 additional check boxes in each section that causes the switch to be programmed as follows:

Group: When checked, the push button is identified as a Group push button. Any motor that has the SDN switch address in its group memory (1 of 16) will respond to commands sent by the push button.

P-P: When checked, the push button will only control that motor whose address is in the P-P Addr field next to the Default Button Destination label at the bottom of the GUI. This is useful when one motor in a group that normally move together needs the ability to be activated (or any other command such as Lock/Unlock) separately.

Specific: Similar to P-P. When checked an additional input box appears in the specific Push Button program box where a motor address can be inputted. This allows the ability of each push button to control a specific motor.

Src Group: When checked, an additional input box appears prompting the programmer to input a group address. This is used when multiple groups require control from a single switch.

Only one of the above for each push button can be active at a time. (Group, P-P, Specific or Src Group)

Seq: The sequence check box transforms the operation of the push button from on press, on hold, on release to Function 1, Function 2, Function 3. This allows sequential operation (Up, Stop, Down, Stop, etc.) for any of the above addressing methods.

Rest of GUI:

With only one switch connected to the network and the check box; **Use Switch Address for Config** unchecked, the present switch configuration can be read or written by clicking **Get Config** and **Send Config** respectively. The **Get Config** will also return the switch address. Before configuring the switch, the parameters must be set in the Input #1 – Input #8 programming boxes.

If the **Use SW P-P Address for Setup** is checked, then the switch address must be known and inputted in the Switch Address field. This is useful when only one switch of many on a network needs to be configured.

Import Config: Use to import a saved switch configuration. This saves time when several switches have the same or similar configuration. Note: address of switches must be known.

Export Config: Use to save a switch configuration.

Compare: Compares File to Screen Setup: Useful for troubleshooting to verify configuration.

4 General Installation Notes

- As already mentioned, the motor and switch addresses should be read and recorded prior to installing the window treatments. This will greatly reduce the amount of time on site commissioning the system.
- Proper motor direction and limits should be set prior to commissioning the system.
- Prior to plugging a lengthened motor data cable into the Tap, it should be checked to make sure the cable is correct by using an ILT switch to move the motor. Note: cable must be straight thru and not crossed.
- A quick way to see if there is power on a segment is to look inside the Tap; a red LED should be illuminated. A switch may also be connected to a segment, the power LED should be illuminated red.
- For commissioning, it is helpful to program all motors with the same switch address in location #16. This way a single switch can control all motors. This will make troubleshooting easier.
- A typical installation is a multi-floor building. For example, if there is a 5 story building with 25 nodes per floor it may not be practical to have one long segment of 125 nodes. More than likely there will be one powered segment per floor terminating in an equipment room. As each segment is powered they can not be “daisy-chained” together using the Taps. In this case the data lines need to be connected together while the power is isolated using punch-down or Keystone jacks as follows:

